



FRESHPOINT[®] GRO-350B

THREE STAGE REVERSE OSMOSIS SYSTEM



APPLICATIONS

- ◆ Drinking water

FEATURES • BENEFITS

- ◆ Reduces more than 90% of contaminants found in water
- ◆ Effortless click-in cartridge change-outs
- ◆ Color-coded cartridges help maintain proper filter sequence
- ◆ 3/8" push fittings for easy installation
- ◆ High efficiency membrane technology delivers up to 50 gallons per day

INSTALLATION TIPS

- ◆ Choose a mounting location suitable to support the full weight of the system when operating.
- ◆ Install vertically with the cartridge hanging down.
- ◆ System may be installed with cartridge flush to the baseboard if desired as the mechanical assist lever pushes cartridges straight out.

OPERATION TIPS

- ◆ Replace pre/post filters every year and RO membrane every 18 months.
- ◆ Place replacement cartridges in proper sequence utilizing color-coded shapes.
- ◆ System designed with integrated check valves so cold water line does not need to be shut-off to perform cartridge change-outs

INCLUDES

- ◆ Air gap side faucet
- ◆ Installation kit
- ◆ Installation and operation manual
- ◆ 3.2 gallon storage tank

FRESHPOINT GRO-350B THREE STAGE REVERSE OSMOSIS SYSTEM

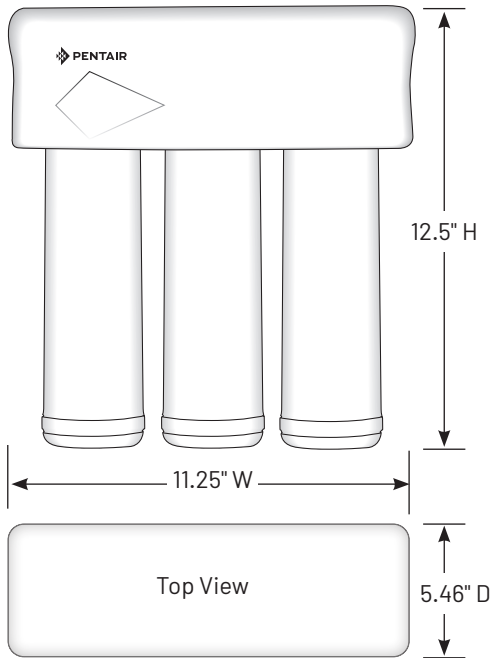

SPECIFICATIONS

- ◆ **System** (Model/Part No.)
GRO-350B/161110
- ◆ **Inlet Size**
3/8" QC
- ◆ **System Dimensions**
12.5" H x 11.25" W x 5.46" D
(317 mm X 285 mm x 139 mm)
- ◆ **System Weight**
7.10 lbs
- ◆ **Contaminant Reduction**
Chlorine Taste and Odor,
Arsenic (Pentavalent) <=50
ppb*, Barium, Cadmium,
Chromium (Hexavalent),
Chromium (Trivalent), Copper,
Fluoride, Lead, Radium 226/228,
Selenium, Turbidity, TDS,
Cyst: NSF/ANSI Standard 58
certified to reduce cysts such
as *Cryptosporidium* and *Giardia*
by mechanical means.
- ◆ **TDS Rejection**
96.90%
- ◆ **Approximate Filter Life***
Pre/Post Filters: 1 Year
RO Membrane: 18 Months
- ◆ **System Production Rate**
14.96 gpd (56.63 Lpd)
(Side Faucet Required)
- ◆ **Recovery Rating**
38.65%
- ◆ **Certifications**
NSF/ANSI Standards 42, 58
CSA Standard B483.1
- ◆ **Feed Pressure Range**
40 - 100 psi (2.75 - 6.89 bar)
- ◆ **Temperature Range**
40 - 100°F (4.4 - 37.8°C)
- ◆ **Replacement Cartridges**
(Model/Part No.)
F1GC-RC/655117-96
FDF1-RC/655123-96
GR050-RC/655121-96

* Filter life dependent on gallon usage and overall incoming water quality.

EPA Est. No. 082989-CHN-001

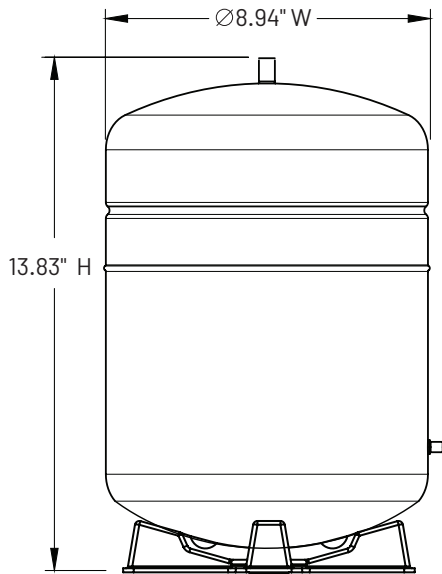

The Model GRO-350B is Tested and Certified by NSF International against NSF/ANSI Standards 42, 58 and CSA B483.1 for the reduction of substances specified in the service manual or at www.nsf.org.



13845 Bishops Dr. | Suite 200 | Brookfield, WI 53005 | United States
P: 262.238.4400 | Customer Service: 800.279.9404 | tech-support@pentair.com | pentair.com

§For a detailed list of where Pentair trademarks are registered, please visit www.pentair.com/registrations. Pentair trademarks and logos are owned by Pentair plc or its affiliates. Third party registered and unregistered trademarks and logos are the property of their respective owners.

© 2020 Pentair Residential Filtration, LLC. All rights reserved.

4004804 Rev C FE20